

SPACE ENVIRONMENT TESTING OF A HEAT PIPE

L. L. Vasil'ev, V. V. Gil',
N. A. Zharikov, V. E. Zelenin,
O. M. Syvorotka, and E. I. Uvarov

UDC 536.58:536.248.2

An experimental heat pipe for spacecraft temperature control systems has been tested in a space environment. The results of the test are described.

In recent years various branches of technology have begun to make widespread use of heat pipes (HP) because of their unique properties of high thermal conductivity and functional flexibility [1-3].

Low-temperature capillary HP (working temperature range up to 400°C) are a promising means of regulating the thermal environment of spacecraft. The United States technical press has reported the successful testing of HP under space conditions. Thus, for example, in the ATS-E they were used to cool and equalize the temperature of solar panels with the object of increasing their efficiency and prolonging their life; in the GEO-B satellite they were used for controlling the temperature of the radio responders; and in the OAO-C orbiting astronomical observatory, for equalizing the temperature field of the structural elements.

There is now an extensive literature, Soviet and foreign, on theoretical and experimental HP research [4-6]. However, their practical construction and application in spacecraft involve certain difficulties. These are largely associated with the lack of comparative experimental data on the operation of HP in conditions of weightlessness and on their expected life in a space environment; questions also remain with regard to the compatibility of structural materials and heat-transfer agents, etc.

The present full-scale experiment on HP performance in conditions of weightlessness was carried out to provide experimental data for the development of HP for spacecraft temperature control systems. For this purpose we used a satellite of the "Interkosmos" series, which imposed certain constraints on the power and size-weight characteristics of the test pipe, as well as on the telemetry system.

The principal design data for the heat pipe, intended for spacecraft body temperature equalization, were as follows: range of operating temperatures T_c — 5 to +50°C; heat flux transmitted at given heat-pipe length and temperature difference $P = 10$ W for a drop of up to 5°C; heat flux density in heating and cooling sections q up to 0.25 W/cm².

Thus it is possible to test the performance and heat conduction characteristics of such a heat pipe under field conditions by ensuring that a heat flux of given power is supplied to the evaporator section and removed from the condenser section and checking the temperature of these sections. For comparison purposes a model should be exposed to similar conditions. This model should be structurally similar (geometry, material) to the test pipe but not supplied with heat transfer agent. In this case a comparative estimate of the temperature drops for the heat pipe and the model will give a good idea of the efficiency of the heat pipe.

In view of the balanced satellite power system and the fact that "Interkosmos 11" was oriented toward the sun, for the purposes of the experiment it was considered desirable to use solar heat energy.

The test specimen (heat-pipe unit) consisted of two autonomous assemblies: the heat pipe and the comparison pipe (model).

The comparison pipe was assembled in the same way as the test pipe, except that the heat transfer agent was omitted.

A. V. Lykov Institute of Heat and Mass Transfer, Academy of Sciences of the Belorussian SSR, Minsk. Translated from *Inzhenerno-Fizicheskii Zhurnal*, Vol. 31, No. 6, pp. 990-995, December, 1976. Original article submitted October 3, 1975.

This material is protected by copyright registered in the name of Plenum Publishing Corporation, 227 West 17th Street, New York, N.Y. 10011. No part of this publication may be reproduced, stored in a retrieval system, or transmitted, in any form or by any means, electronic, mechanical, photocopying, microfilming, recording or otherwise, without written permission of the publisher. A copy of this article is available from the publisher for \$7.50.

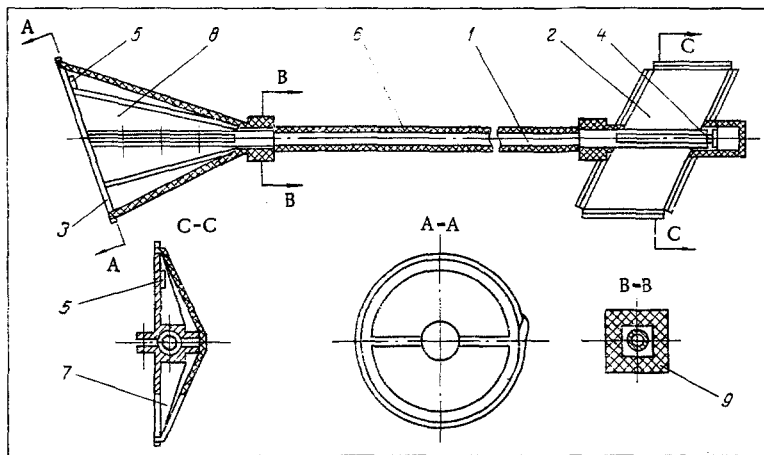

Fig. 1. Details of heat-pipe construction: 1) heat pipe; 2) collector; 3) radiator; 4) filler; 5) temperature sensors; 6) thermal insulation; 7) collector fins; 8) radiator fins; 9) heat-insulating inserts.

The heat-pipe assembly comprised (Fig. 1): the heat pipe proper 1, the collector 2, the radiator 3, the filler 4, temperature sensors 5 (two), and thermal insulation 6.

The body of the heat pipe was made of a 12×1 tube, 730 mm long, of AMg-3-M aluminum alloy. The capillary structure was formed by a series of cylindrical corrugated inserts (corrugations parallel to the axis). These inserts were made from steel strip (Cr18Ni10Ti-M) 0.2 mm thick.

As the heat-transfer agent we used Freon-11 with the solid impurities removed (12.5 cm^3 , volume of liquid at 20°C), dosing accuracy $\pm 5\%$. After being filled, the heat pipe was sealed by soldering up the filler tube with PSr-72 solder and setting the filler plug in AK-20A adhesive.

The collector, designed to collect solar heat energy and supply it to the heat pipe, took the form of a flat rhombic panel of AMg-6-B-M aluminum alloy (3-mm sheet). Its heat-absorbing surface was coated with AK-512 black enamel, and fins 7, for improving the heat transfer to the heat pipe, were welded to the back.

The radiator, designed to remove from the heat pipe the heat flux transmitted by the collector and to radiate it into space, was a flat disk of AMg-6-B-M aluminum alloy (3-mm sheet). Its radiating surface was coated with AK-512 white enamel, and, like the collector, it had fins 8 welded to the back to improve the heat transfer.

The areas of the coated collector and radiator surfaces were, respectively, calculated to absorb 10 W of solar radiant flux and radiate it into space.

Thermal contact between the collector and radiator with the body of the heat pipe was achieved on pipe sections each 130 mm long.

The uncoated surfaces of the collector and radiator and the surface of the heat pipe were covered with vacuum-screen thermal insulation.

The temperature sensors (resistance thermometers) were mounted on the collector and radiator surfaces under the thermal insulation.

The heat pipe and the comparison pipe were mounted outside the sealed satellite compartment (Fig. 2) in such a way that in orbital flight the coated surfaces of the collectors were exposed to direct sunlight and served as heaters; the coated surfaces of the radiators were oriented in a plane parallel to the sun's rays and radiated the heat flux transmitted to them from the collectors.

In order to reduce conductive heat transfer between the test objects and the structure of the satellite, foam-plastic insulation 9 was incorporated in the supporting brackets (Fig. 1).

The temperature sensors were connected to the memory of the satellite radiotelemetry system.

Ground testing of the heat-pipe unit (HPU) included a check on its functioning under simulated operating conditions. This involved the determination of the thermal performance of the heat pipe and comparison pipe at various collector powers (0, 10, and 20 W) and various initial temperatures (-5 , $+20$, and $+50^\circ\text{C}$).

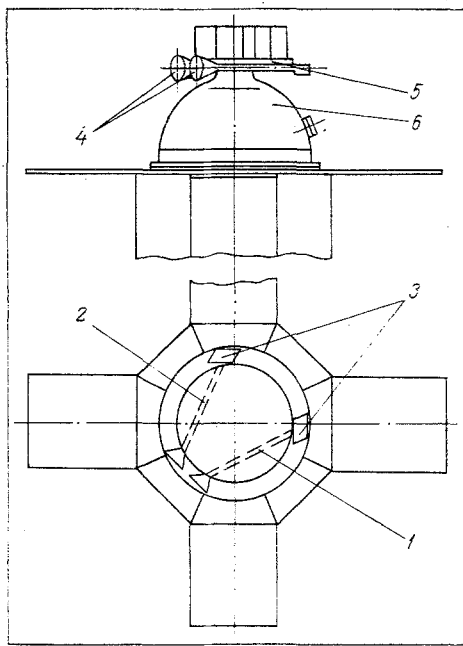

Fig. 2. Mounting of heat-pipe unit:
 1) heat pipe; 2) comparison pipe;
 3) collectors; 4) radiators; 5) in-
 strument platform; 6) satellite.

The tests were carried out in a 2-m³ pressure chamber equipped with:

- a) a two-stage vacuum pump system capable of creating and maintaining a vacuum of $2 \cdot 10^{-5}$ mm Hg;
- b) a pressure monitoring system;
- c) a system for supplying a specified heat flux to the collector, comprising a resistance heater, a variable power supply, switching elements, and a system for measuring the heater power input;
- d) a system for removing heat from the radiator, comprising a liquid-nitrogen-cooled screen and a liquid-nitrogen supply system;
- e) a temperature measuring system, comprising Chromel—Copel thermocouples, automatic recording potentiometers, and corresponding measuring lines;
- f) a special device for adjusting the position of the test object in the pressure chamber (difference in end levels not more than 1 mm) and for adjusting the position of the liquid-nitrogen-cooled screen relative to the emitting surface of the radiator.

The required initial temperature was obtained by blowing preheated or precooled air, from which the oil and dust had been removed, over the test object.

The experimental results are summarized in Table 1. An analysis of these results showed that on the given range of operating temperatures the heat pipe will transmit a heat flux of up to 20 W at a temperature drop along its length (measured at the points where the pipe enters the radiator and the collector) of not more than 2-3°C, which corresponds to the design characteristics, whereas for the comparison pipe the drop was up to 67°C. There are considerable temperature drops on the collector—pipe and radiator—pipe body sections, totaling up to 25°C for the heat pipe and up to 102°C for the comparison pipe.

Telemetric information concerning the functioning of the HPU forming part of the orbiting satellite "Interkosmos-11" was analyzed during the launch period from May 17, 1974 to October 1, 1974.

During this period the maximum collector—radiator temperature drops were 31.5°C for the heat pipe and 125°C for the comparison pipe, which clearly illustrates the efficiency of the heat pipe and is in quite good agreement with the ground test data in near-steady regimes.

The minimum collector—radiator temperature drop recorded for the heat pipe was 1°C; in this case the corresponding figure for the comparison pipe was 49°C.

The maximum collector—radiator temperature drops for the heat pipe at the beginning and the end of the ground tests were practically the same (31 and 31.5°C, respectively).

TABLE 1. Test Results

Test conditions		Object	$T_1, ^\circ\text{C}$	$T_2, ^\circ\text{C}$	$T_3, ^\circ\text{C}$	$T_4, ^\circ\text{C}$	$T_2 - T_3, ^\circ\text{C}$	$T_1 - T_4, ^\circ\text{C}$
In pressure chamber	$T_c = 20^\circ\text{C}$ $P = 10.2\text{ W}$	HP	36	27	25	16	2	20
		CM	73	53	-4	-11	57	84
	$T_c = -5^\circ\text{C}$ $P = 10.2\text{ W}$	HP	30	22	20	11	2	19
		CM	72	54	-12	-27	66	99
	$T_c = 50^\circ\text{C}$ $P = 10.3\text{ W}$	HP	40	33	31	21	2	19
		CM	76	58	3	-6	55	82
In space	$P_d = 10\text{ W}$	HP	53	—	—	30	—	23
		CM	93	—	—	-9	—	102
		HP	42	—	—	24	—	18
		CM	75	—	—	-12	—	87
		HP	14	—	—	13	—	1
		CM	35	—	—	-14	—	49
		HP	58	—	—	32	—	26
		CM	95	—	—	-9	—	104
		HP	40	—	—	29	—	11
		CM	80	—	—	-3	—	83

Thus a comparative analysis of the results of testing an experimental heat pipe for spacecraft temperature control systems in a pressure chamber and on the "Interkosmos-11" satellite has confirmed its effectiveness under conditions of weightlessness. The heat-transfer characteristics of the heat pipe tested under conditions of weightlessness are similar to those obtained in ground tests; no deterioration was noted in the course of 4.5 months operation in space.

NOTATION

T , temperature, $^\circ\text{C}$; $T_2 - T_3$, $T_1 - T_4$, temperature drops along heat pipe between collector and radiator inlets and between collector and radiator, respectively, $^\circ\text{C}$; T_c , ambient temperature, $^\circ\text{C}$; P , heat flux transported by heat pipe, W ; q , heat flux density, W/cm^2 ; HP, heat pipe; CM, comparison model.

LITERATURE CITED

1. A. P. Shlosinger, T. R. W. System Group, Redondo Beach, Calif. NASA CR-1400 (1969).
2. G. F. Smirnov, *Inzh.-Fiz. Zh.*, 28, No. 2 (1975).
3. V. Binert, in: *Heat Pipes [Russian translation]*, Mir, Moscow (1972).
4. E. Baker, "Prediction of long-term heat-pipe performance from accelerated life tests," *AIAA J.*, 11, No. 9, 1345-1347 (1973).
5. Ya. S. Kadaner and Yu. P. Rassadkin, *Inzh.-Fiz. Zh.*, 28, No. 2 (1975).
6. V. V. Gil', O. M. Syvorotka, and A. D. Shnyrev, in: *Intensification of Energy- and Mass-Transfer Processes in Porous Media at Low Temperatures [in Russian]*, ITMO, Akad. Nauk BelorusSSR, Minsk (1975).